

201-301 Oil Burner

Note: Parts may not be exactly as shown in diagram.

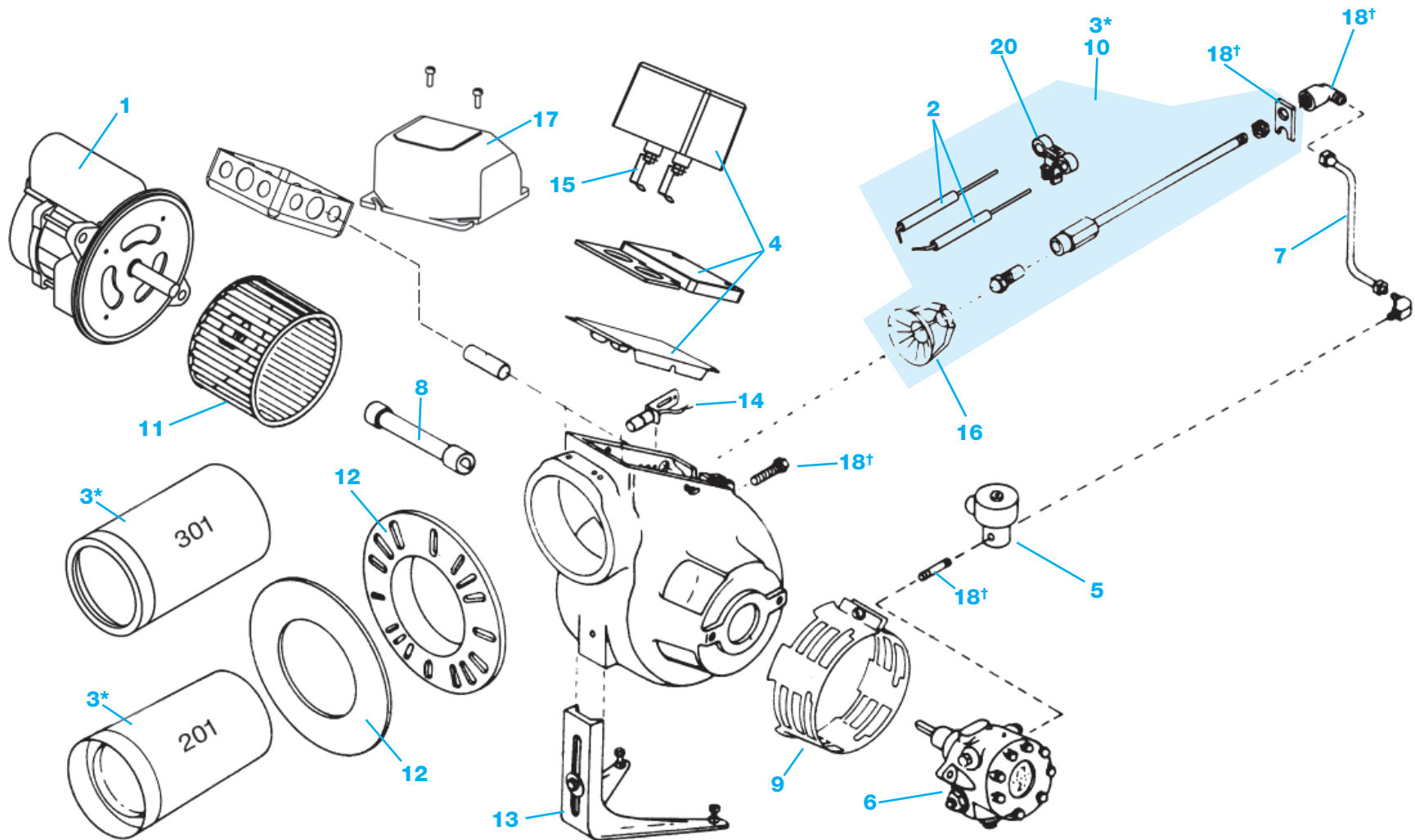

*3 includes selected air tube and combustion head assembly

†18 includes multiple parts

201- 301 Oil Burner

ITEM	PART NO.	DESCRIPTION	201CRD	301CRD
1	98630S	1/4 hp, 120V, 60HZ, 48N Frame Motor	•	•
2	82776S	Electrode Set (2), 7/6" Nominal, Approx. 8-1/2" OAL	•	•
	82784S	Electrode Set (2), 9/8" Nominal, Approx. 10-3/4" OAL	•	•
	82792S	Electrode Set (2), 11/10" Nominal, Approx. 12-1/2" OAL	•	•
	82818S	Electrode Set (2), 15/14" Nominal, Approx. 16-1/2" OAL	•	•
	82826S	Electrode Set (2), 18/17" Nominal, Approx. 19-1/2" OAL	•	•
3	22046S	201CRD 7" Air Tube/Combustion Head Assy	•	
	22053S	201CRD 9" Air Tube/Combustion Head Assy	•	
	22012S	201CRD 11" Air Tube/Combustion Head Assy	•	
	22020S	201CRD 15" Air Tube/Combustion Head Assy	•	
	22293S	301CRD B-Style 6" Air Tube/Combustion Head Assy		•
	22327S	301CRD B-Style 8" Air Tube/Combustion Head Assy		•
	22202S	301CRD B-Style 10" Air Tube/Combustion Head Assy		•
	22236S	301CRD B-Style 14" Air Tube/Combustion Head Assy		•
	22442S	301CRD C-Style 6" Air Tube/Combustion Head Assy		•
	22475S	301CRD C-Style 8" Air Tube/Combustion Head Assy		•
	22350S	301CRD C-Style 10" Air Tube/Combustion Head Assy		•
22384S	301CRD C-Style 14" Air Tube/Combustion Head Assy		•	
4	41000S	110V Ignitor	•	•
	41000S0SC	110V Ignitor on Baseplate	•	•
5	SVC10FFS	Oil Valve	•	•
	98289S	Oil Valve Kit with fittings	•	•
6	23234S	Fuel Unit, 1 Stage, A2YA-7916 100PSI	•	•
	74443S	Fuel Unit, 1 Stage, NYC, A2YA-7916 100PSI	•	•
	74443HPS	Fuel Unit, 1 Stage, NYC, A2YA-7916 150PSI	•	•
	23267S	Fuel Unit, 2 Stage, B2YA-8916 100PSI	•	•
	74459S	Fuel Unit, 2 Stage, NYC, B2YA-8916 100PSI	•	•
	74559HPAS	Fuel Unit, 2 Stage, NYC, B2YA-8916 140PSI	•	•
	74559HPS	Fuel Unit, 2 Stage, NYC, B2YA-8916 150PSI	•	•
7	34785S	Oil line kit (incl. all oil lines)	•	•
8	28720S	Fuel Unit Coupling	•	•
9	47001S	201/301CRD 4-slot Air Band	•	•

ITEM	PART NO.	DESCRIPTION	201CRD	301CRD
10	54155S	7" Nominal, 16-3/4" OAL Combustion Head Assy	•	
	54205S	9" Nominal, 18-3/4" OAL Combustion Head Assy	•	
	53975S	11" Nominal, 20-3/4" OAL Combustion Head Assy	•	
	54031S	15" Nominal, 24-5/16" OAL Combustion Head Assy	•	
	55574S	6" Nominal 16-3/4" OAL Combustion Head Assy		•
	55616S	8" Nominal 18-3/4" OAL Combustion Head Assy		•
	55434S	10" Nominal 20-3/4" OAL Combustion Head Assy		•
	55491S	14" Nominal 24-3/4" OAL Combustion Head Assy		•
11	28563S	Blower wheel/ fan, 5-3/4" OD x 4" W, 1/2" BORE	•	•
12	23259S	4" Universal Flange & Gasket	•	•
	23184S	4" Pressure Flange & Gasket	•	•
13	23358S	Pedestal w/ hardware	•	•
14	14407S0ES	CAD Cell Kit	•	•
15	41DTK01S	Universal Ignitor Terminal kit	•	•
16	55418S	Retention Ring Assy 201CRD	•	
	55715S	Retention Ring Assy 301CRD		•
17	70200S	Universal Primary w/ Display 70200	•	•
	4020002S	Model 40200 Primary 30/15/30	•	•
	5020002S	Model 50200 Primary 30/15/30	•	•
	6020002S	Model 60200 Primary 15/15/15	•	•
18	2301KITS	Hardware Kit (Yoke, CH elbow, OV Nip, CH Adj screw)	•	•
19	47035S	Pressure Augmentor (not shown)	•	•
20	59881S	Electrode Bracket	•	•