

# BLF9201 SERIES

## LEAD FREE

### FORGED BRASS BALL VALVE

A forged brass quarter turn valve, rated 600 WOG, two piece, full port, with solder joint end connections. Valve conforms to and is CSA certified to ASME A112.18.1.

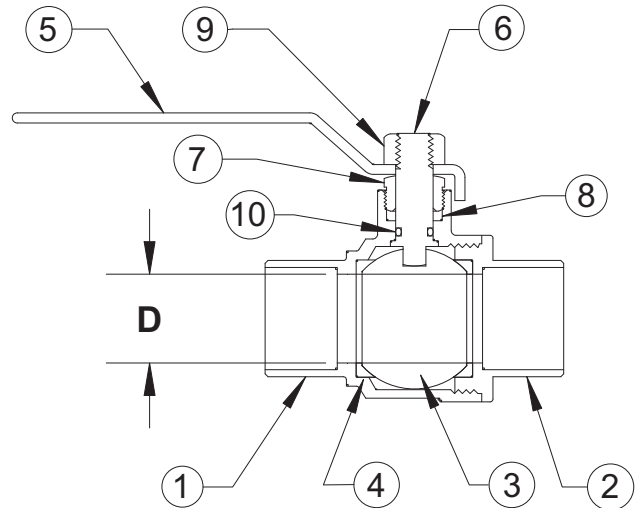
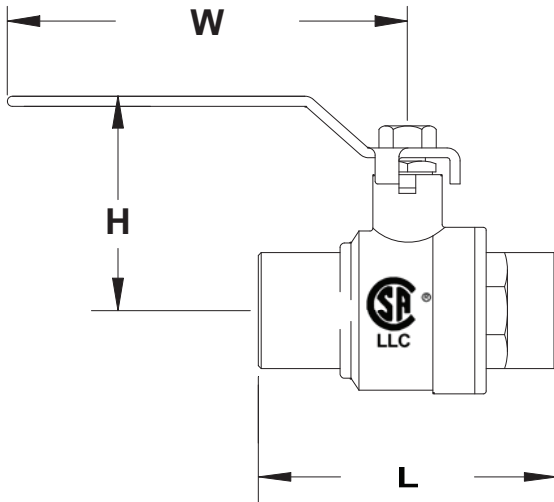

### DIMENSIONS

CAT. NO.	SIZE	L	D	H	W
BLF0509201	1/2	2.17	.59	1.77	3.35
BLF0759201	3/4	2.82	.75	2.05	4.35
BLF1009201	1	3.28	1.00	2.20	4.35
BLF1259201	1 1/4	4.06	1.25	2.50	5.65
BLF1509201	1 1/2	4.32	1.57	2.70	5.65
BLF2009201	2	5.45	1.97	3.23	5.65

PRESS. VS. TEMP. CURVE

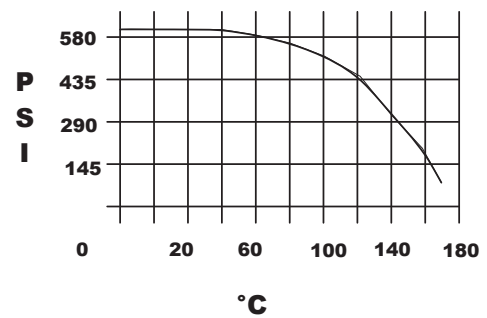

### MATERIAL LIST

NO.	PART NAME	BLF SERIES
10	O-RING	VITON
9	NUT	ZINC PLATED STEEL
8	STEM PACKING	PTFE
7	GLAND NUT	BRASS C37700
6	STEM	TYPE 304 SST
5	HANDLE	ZINC PLTD STEEL, PLASTICOATED
4	SEAT	PTFE
3	BALL	TYPE 304 SST
2	END CAP	BRASS C46400
1	BODY	BRASS C46400

BOSTON METAL PRODUCTS, LTD. - 25 THURBER BLVD., UNIT #3 - SMITHFIELD, RI 02917  
 TOLL FREE: 1-800-839-0013, TEL: 401-231-8537, FAX: 401-231-8491  
 WWW.BOSTONVALVE.COM