



R182J, R482J, R845A, R847A, R882J, RA89A, RA832A Switching Relays

INSTALLATION INSTRUCTIONS

APPLICATION

These relays can be used for a variety of switching applications to provide control of line- or low-voltage devices by a low voltage controller. See Table 1.

Table 1. Switching Relay Specifications.

Models	Application	Voltage (50/60 Hz)	Switch Action	Control Circuit	Coil Voltage (Vac at 50/60 Hz)	Relay Coil Current (A)	Contact Ratings (A)	
							AFL	ALR
R182J	For 24V thermostat control of line voltage devices.	120	Dpdt	3-wire	24	0.40 ^a	7.4	44.4
		240					3.7	22.2
R482J	Controlled by a line voltage controller	120		2-wire	120	0.08	7.4	44.4
		208/240					3.7	22.2
R845A	For hot water zone control systems or spst control of two separate loads.	120	Dpst		24	0.40	7.4	44.4
R847A	Provides switching for high-current loads such as cooling compressors.	120					22	100
		240					10	50
R882J	For use with separate low voltage power source.	24	Dpdt				7.4	44.4
RA89A	For switching one line voltage load.	120	Spst				10.2	61.2
RA832A	For switching two line voltage loads with a common power source.	120	Dpst				7.4	44.4
		240					3.7	22.2

^a IMPORTANT:

The transformer on the R182 can overheat when used with a series 20 thermostat if the total resistance of the thermostat circuit exceeds 2.5 ohms. If the measured resistance of the thermostat (including thermostat wire and thermostat contact resistance) exceeds 2.5 ohms, add a 100 ohm, 10 watt resistor between the W and R terminals. Table 2 gives maximum thermostat wire runs; if longer runs are necessary, measure the resistance or add a 100 ohm, 10 watt resistor across terminals W and R.

Table 2. Length of Wire.

AWG Wire Size (Number)	Total Wire Length		Length of Run to Thermostat (Wires)	
	Feet	Meters	Feet	Meters
22	120	38.0	60	18.0
20	200	61.0	100	30.5
18	300	91.5	150	45.5
16	500	152.5	250	76.0
14	800	244.0	400	122.0



INSTALLATION

When Installing This Product...

1. Read these instructions carefully. Failure to follow instructions can damage the product or cause a hazardous condition.
2. Check the ratings given in the instructions and on the product to make sure the product is suitable for your application.
3. Make sure installer is a trained, experienced service technician.
4. After completing installation, use these instructions to check out product operation.

⚠ WARNING

Electrocution hazard can cause property damage, severe injury, or death.
Transformer core not bonded. Disconnect power supply before wiring to prevent electrical shock or equipment damage.

Mounting

For replacement, mount the relay in the same location as the old relay. If this is a new installation, locate the relay vertically on a solid wall or partition as close as possible to the device to be controlled. Select a location that is easily accessible for installation and service.

NOTE: To reduce the possible transformer hum and relay noise that is sometimes amplified by mounting surfaces such as sheetmetal, plasterboard, and similar materials, place rubber or felt washers between the case and the mounting surface.

1. Position the relay and mark the mounting holes. See Fig. 1.
2. Start a screw for the keyhole type mounting hole in the upper right corner. Screw it down within about 1/8 in. [3 mm] of the surface.
3. Hang the relay on the screw, position the case, and start the bottom screw.
4. Tighten both screws.

Wiring

All wiring must comply with all applicable electrical codes, ordinances, and regulations. Follow any instructions furnished with the controlled equipment.

IMPORTANT:

The switching relay terminals are approved for use with copper wires only.

See Fig. 2 through 10 for hookup diagrams for these relays. When two or more devices are to be controlled in parallel, the total current must not exceed the relay load rating. Fig. 11 is an internal view of the RA832A and shows terminal locations and barriers.

Never connect load terminals to a load that takes more current than the amount listed in the electrical ratings on the relay.

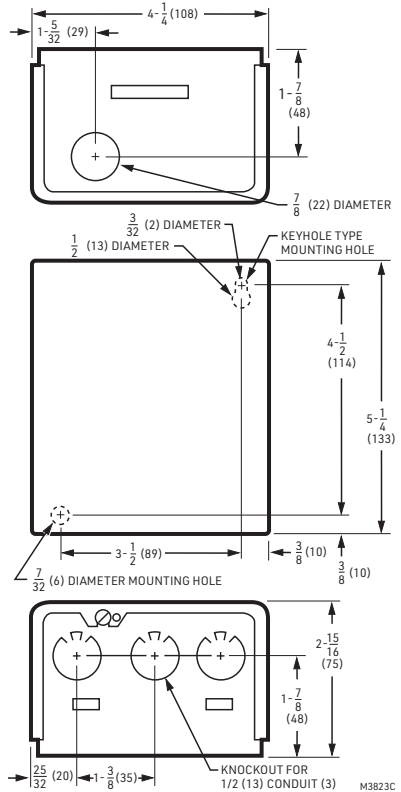
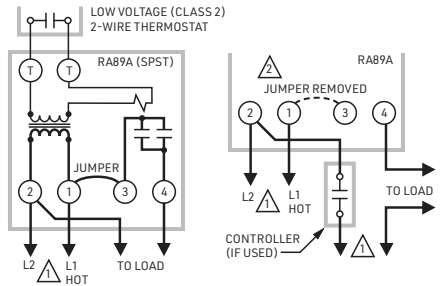

Fig. 1. Approximate mounting dimensions in in. (mm).



- ⚠ POWER SUPPLY. PROVIDE OVERLOAD PROTECTION AND DISCONNECT MEANS AS REQUIRED.
- ⚠ COMPLETE WIRING AS SHOWN ABOVE.

Fig. 2. Internal schematic and typical hookup for RA89A.

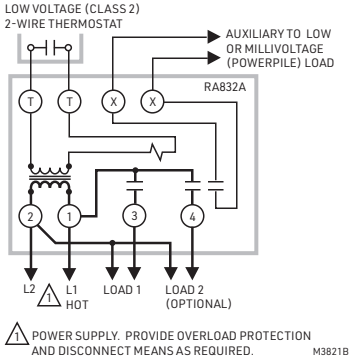

Fig. 3. Internal schematic and typical hookup for R832A.

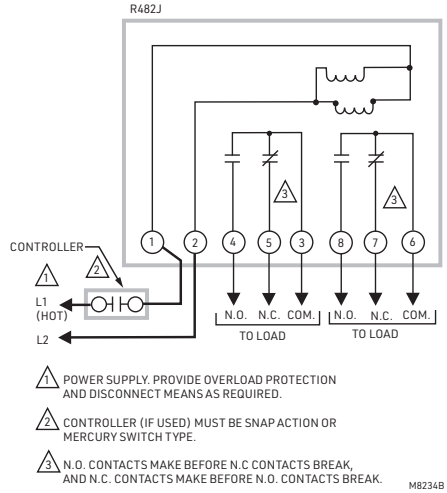

Fig. 6. Internal schematic and typical hookup for R482J.

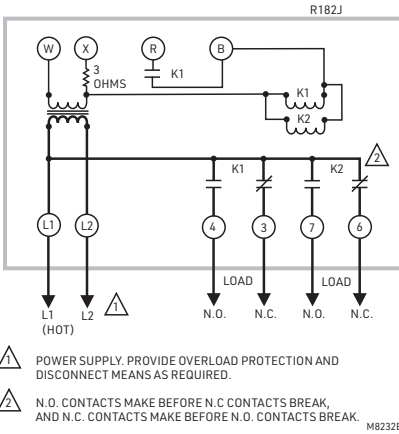

Fig. 4. Internal schematic and typical hookup for R182J.

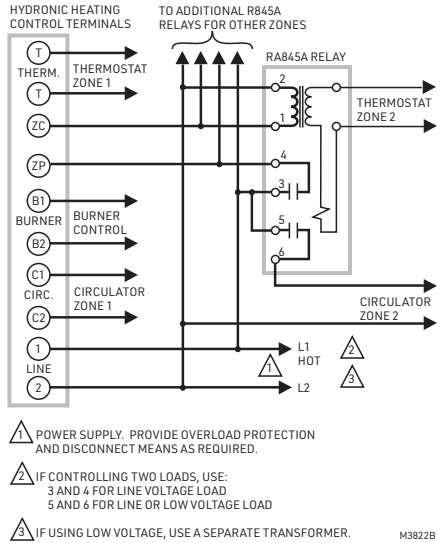

Fig. 7. Schematic diagram showing R845A in multizone, forced hydronic heating system. This arrangement is suitable for any number of additional zones.

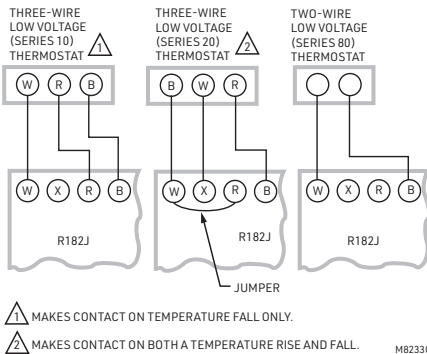

Fig. 5. Thermostat connections for R182J.

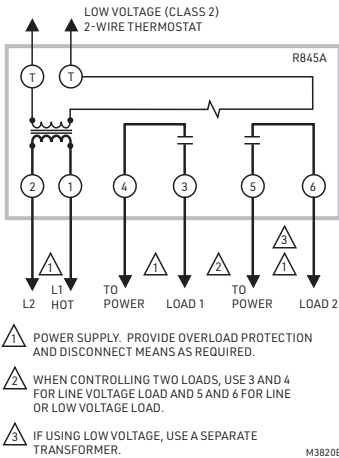

Fig. 8. R845A hookup for controlling two loads.

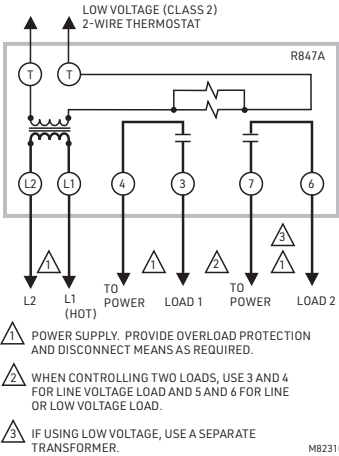

Fig. 9. Internal schematic and hookup for R847A.

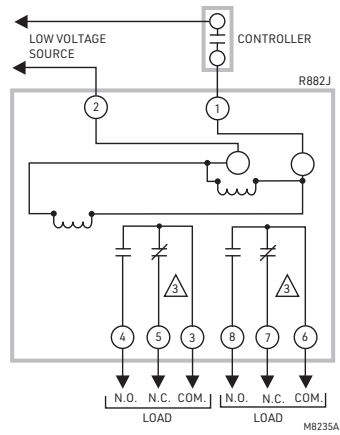

Fig. 10. Internal schematic and hookup for R882J.

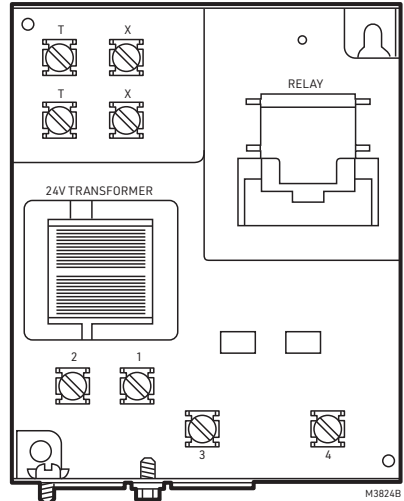

Fig. 11. Internal view of RA832A Switching Relay.

SERVICE AND CHECKOUT

1. Never use oil on any part of the relay coil or contacts.
2. Keep the cover on the relay during normal operation and remove only for service and checkout.
3. Relay contacts require no cleaning; they are arranged so they close with a wiping action and are self-cleaning. The contacts may turn black after being in service for some time; this discoloration does not prevent proper operation.
4. After installation is complete, operate system through at least one cycle from the controller to make certain the relay controls the equipment as intended.