



COMBUSTION AIR SYSTEM

Model: CAS-2B, 2C & 2W



4" VRV



AIR BOOT™



4" IAH HOOD

ITEMS INCLUDED IN KIT:

- 1 - Air Boot™
- 1 - Set of Gaskets
- 1 - 4" VRV
- 1 - 4" IAH Hood
- 1 - Burner Coupling Set
- 2 - Mounting Bolts
- 1 - Flow Restrictor Pan (CAS-2B ONLY)

INSTALLER SUPPLIED ITEMS:

- Duct Piping and Elbows
- 90° Elbows;
- ¼" NPT Female x ¼" NPT Male for routing oil line

This product is designed for use on the following burners, for the purpose of routing combustion air directly to the burner, with the added safety feature of the vacuum relief valve.

NOTE: For burner inputs up to 2.0 GPH at 100 PSI input pressure or equivalent.

This device MUST be installed by a qualified agency* in accordance with the manufacturer's installation instructions.

The definition of a qualified agency is: *any individual, firm, corporation or company which either in person or through a representative is engaged in, and is responsible for, the installation and operation of oil appliances, who is experienced in such work, familiar with all the precautions required, and has complied with all the requirements of the authority having jurisdiction.*

"The Air Boot™ models CAS-2B, CAS-2C and CAS-2W are for use only on the designated burner(s) as described in these instructions only when the specific burner includes this Air Boot™ when shipped from the burner manufacturer or where the burner instructions specifically reference the models CAS-2B, CAS-2C or CAS-2W Air Boot™ as an optional air intake system."

NOTE: This product brings combustion air only to the burner; must have adequate venting air in accordance with NFPA-31.

CAS-2B	BECKETT-AF/AFG
CAS-2C	CARLIN-EZ-1/CRD/FRD
CAS-2W	WAYNE-MSR



FIELD CONTROLS

The Venting Solutions Company™

2630 Airport Road · Kinston, NC 28504
Phone: 252-522-3031 · Fax: 252-522-0214
www.fieldcontrols.com

THE PURPOSE OF THE VRV

The Vacuum Relief Valve is a safety device to guard against combustion problems associated with directly connecting oil burners to the outside. Typical problems can be caused by blockage of the intake termination, icing up of the duct work and effects of leeward side wind effects on a building.

VRV OPERATION

The VRV gate operates on changes in the vacuum pressure generated by the inlet to the oil burner. The VRV gate will remain closed during normal burner operation. During an abnormal operation (i.e., blockage of the intake or change in external building pressures) an increased negative pressure on the intake of the burner causes a reduction in burner air flow. Under this condition, the VRV gate opens, stabilizing and maintaining proper air flow to the burner. The VRV gate closes again once the abnormal condition is corrected.

INSTALLATION

1. Remove the oil pump and air bands from the burner housing. Install the sealing gaskets onto the burner housing. Failure to install the ring gasket onto the burner housing will result in unlevel boot, noisy operation, and improper CO² readings. (See Figure 1) Install mounting spacer onto Air Boot™. (See Figure 2) Position the Air Boot™ over the burner housing on the intake. The Air Boot™ can be mounted onto the burner in a horizontal or vertical position. Install mounting spacer onto Air Boot™. Align the holes in the

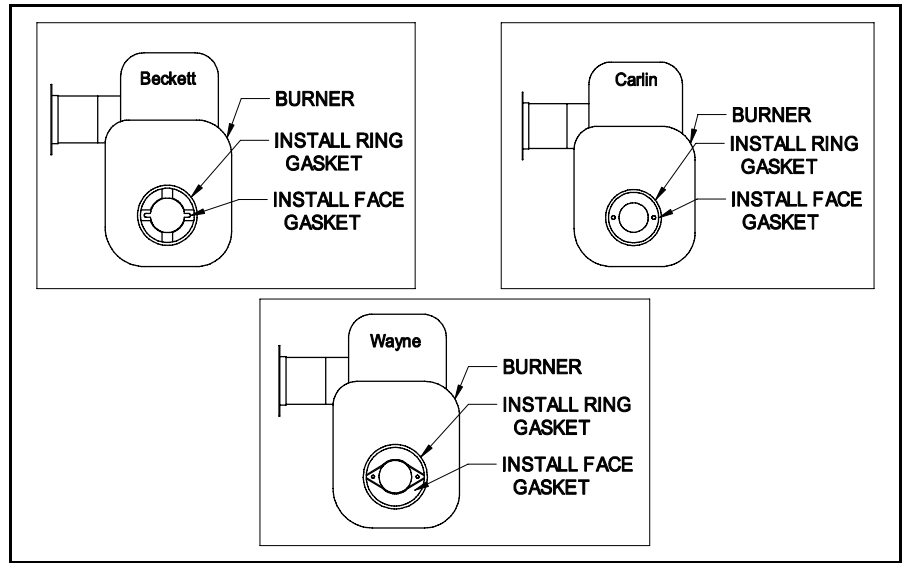

Figure 1

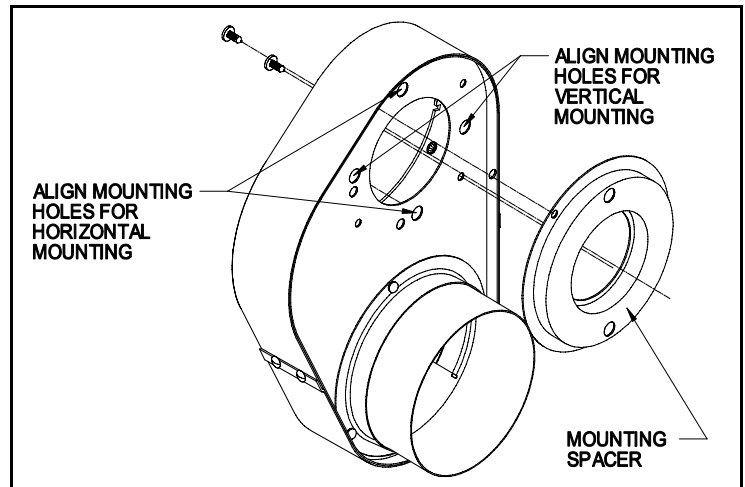

Figure 2

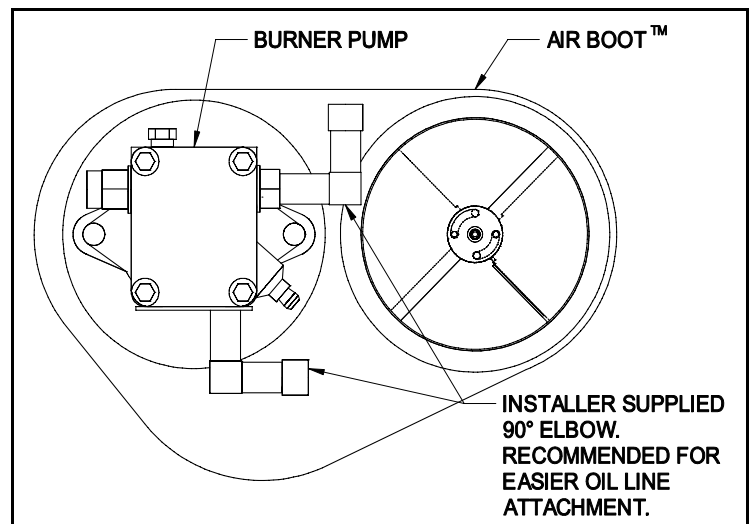

Figure 3

Air Boot™ with the holes in the housing and re-attach the oil pump. (See Figure 3) Important: *Replace pump coupling with the coupling supplied with kit or pump operation problems may occur.* Note that the Air Boot™ may be oriented either vertically or horizontally as space allows. The round spacer plate attached to the Air Boot™ must be removed and rotated 90° if vertical mounting is needed.

2. FOR LOW FIRING RATE APPLICATIONS WITH BURNER INPUTS UP TO .75 GPH (CAS-2B ONLY)

- a. Insert flow restrictor pan in the inlet collar with the flat of the pan inward. (See Figure 4)
- b. Push the pan in all the way, approximately 5/8" from the air adjustment blades. (See Figure 5) Mount VRV tee assembly or 90° elbow onto the Air Boot™ intake. Fasten using three (3) sheet metal screws spaced 120° apart on all joints. (See Figure 6)

3. Assemble VRV balance weight onto the gate. Screw the weight all the way in. Then attach lock nut and knurl nut. (See Figure 7)

4. Mount the VRV assembly onto the tee and fasten with a screw and nut in collar tabs. To ensure proper operation, check the gate for being level across the pivot points and plumb. (See Figure 8)

5. Refer to Figure 9 for general installation layout.

TERMINATION LOCATION GUIDELINES

1. Mount intake hood 12 inches above finished grade. If mounting on the side of a building prone to drifting snow, mount 12 inches above the snow line.
2. Mount at least 12 inches from either side of the vent termination and on the same wall if sidewall venting.
3. Always mount with the inlet vent termination opening pointing down.

NOTE: *Make sure hood is kept free of debris.*

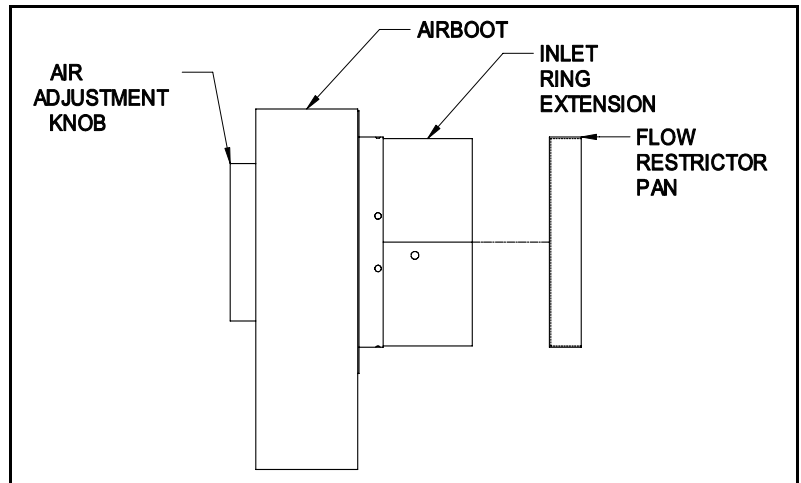

Figure 4

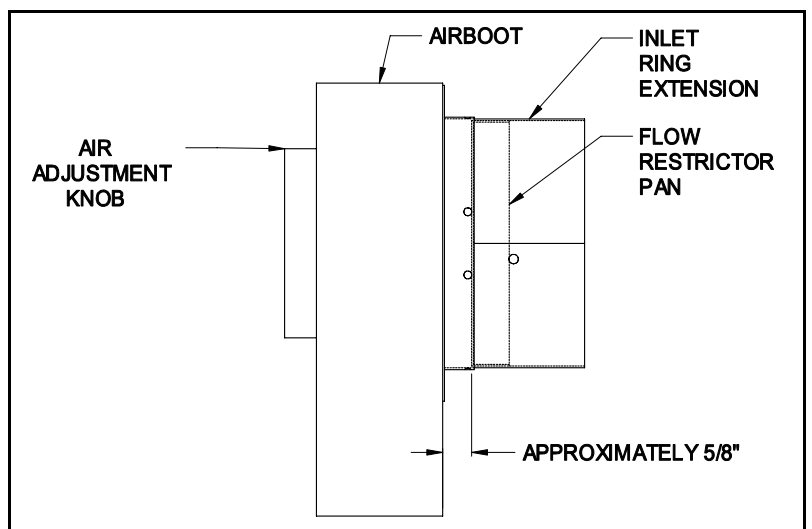

Figure 5

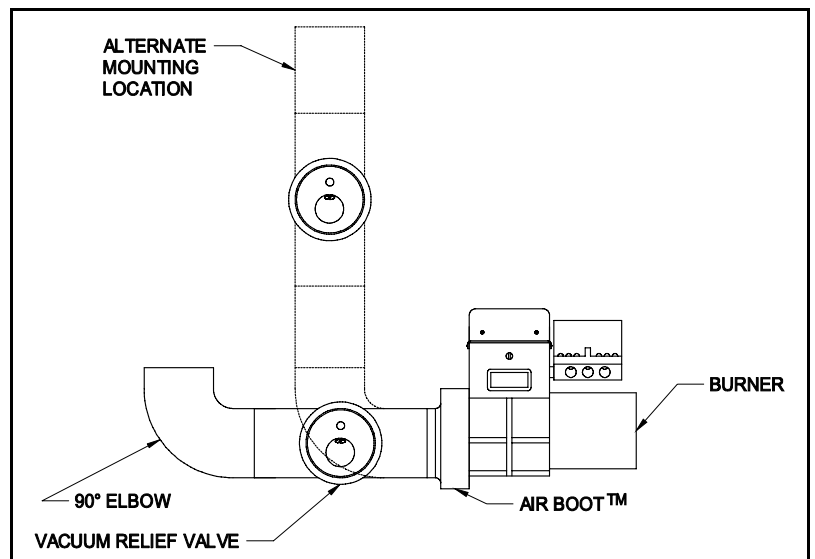

Figure 6

INLET VENT TERMINATION INSTALLATION

1. Cut a 4-1/4" diameter hole through the sidewall of the building.
2. Slide the inlet vent pipe through the hole and fasten to the wall with appropriate fasteners. Seal the edges of the mounting plate with a silicone sealant or equivalent.

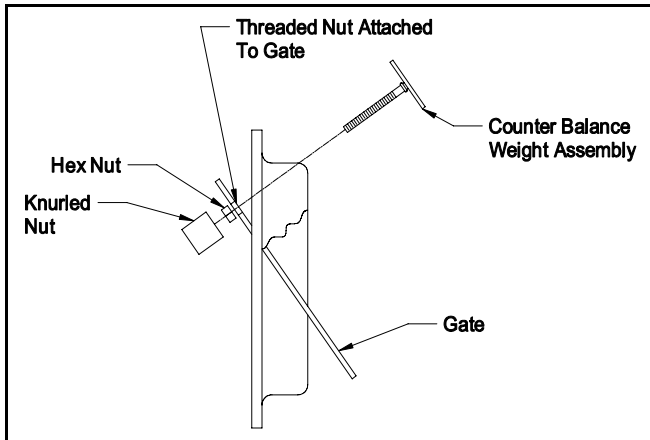

Figure 7

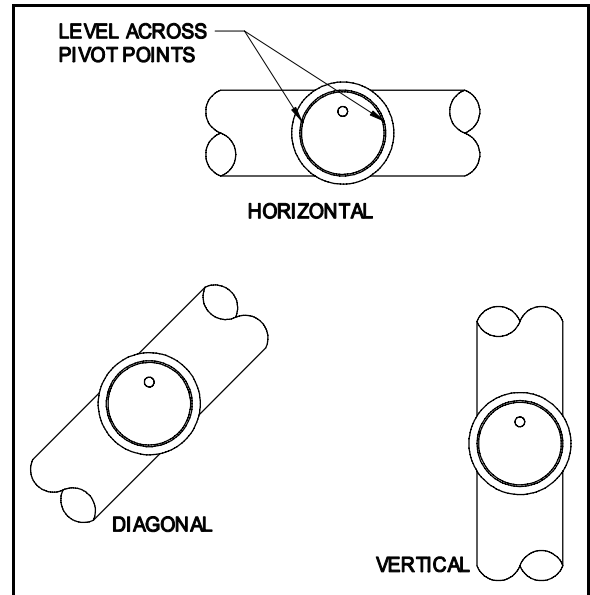

Figure 8

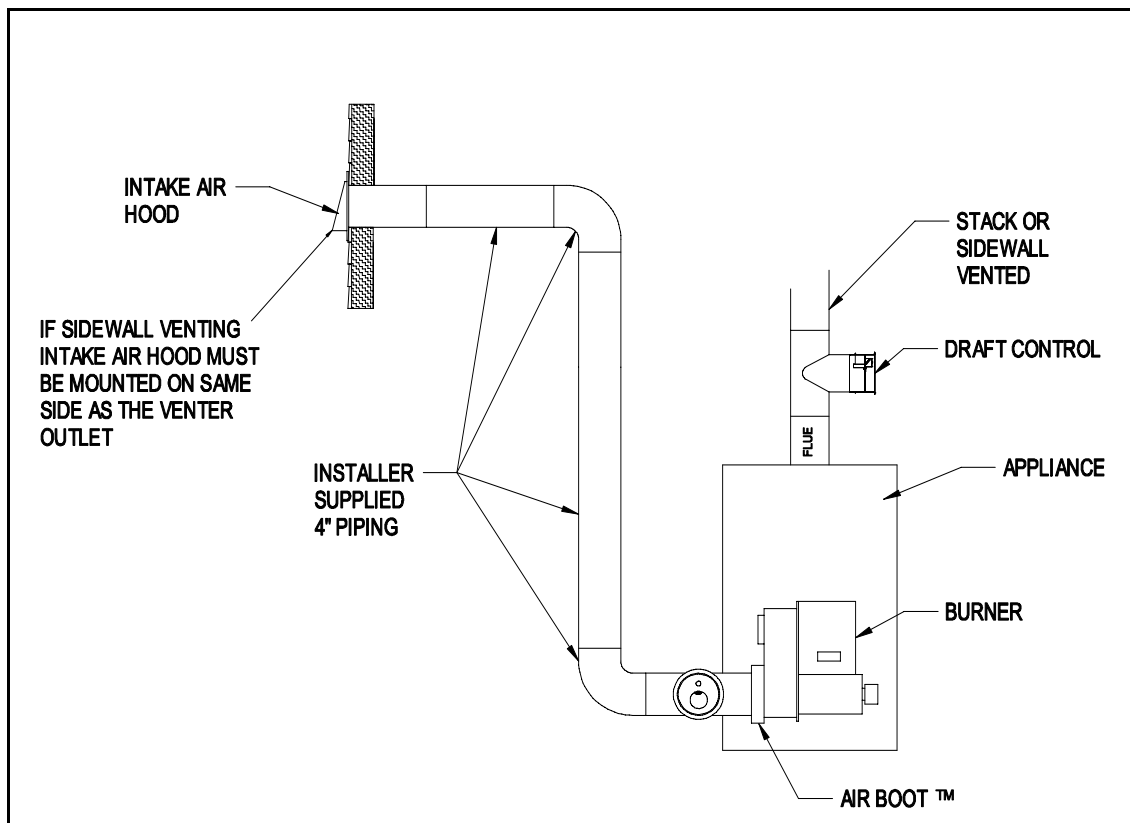

Figure 9

DUCT WORK INSTALLATION

1. Duct length distance, a maximum of 30 linear feet of standard duct pipe and two (2) 90° elbows at maximum firing rate. Subtract 7 feet from the maximum linear feet for every 90° elbow added.

Longer pipe lengths require the use of a larger pipe between the VRV and the intake hood. It also requires the use of a vent pipe increaser at the VRV and a reducer at the intake hood. (See Table 1)

Table 1

Pipe Diameter	Maximum Equivalent Pipe Feet (between Air boot™ and duct termination)	Elbow* Equivalent Feet	Reducer or Increaser Equivalent Feet
4"	44'	7'	-
5"	60'	9'	(4" to 5") 3'
6"	90'	11'	(4" to 6") 6'
*Note: Subtract the elbow or reducer equivalent feet from the maximum equivalent feet to get maximum linear feet of pipe.			

2. Route the duct work from the VRV tee to the inlet vent termination with as minimum a number of elbows as possible.
3. Secure and support the duct work for the design and weight of the material used, to prevent physical damage and separation of joints. For guidelines refer to recognized national building codes or according to any local codes.
4. To reduce uncontrolled air leakage into the duct, tape all joints and seams using standard duct tape.

NOTE: Try to run a minimum of 12 feet of duct to help temper the outside air being brought into burner.

AIR ADJUSTMENT

1. Adjust the air adjustment knob on the side of the Air Boot™ (See Table 2) to rough air setting.

NOTE: For proper burner operation, burner should be set up by using a combustion analysis test set.

Table 2

ROUGH AIR SETTING			
GPH	Knob Setting		
	CAS-2B	CAS-2C	CAS-2W
.75	25°	15°	70°
1.00	60°	25°	90°
1.50	160°	105°	135°

2. Start the burner and adjust the air control as needed to achieve the required CO₂ and smoke levels. Set over fire draft to appliance manufacturers' specifications (typically -.02" of water). Secure air control knob with indicator bracket. If draft levels are not obtainable or controllable, use standard industry methods to control the draft or call the Field Controls Tech Line at 1-800-742-8368 for more information, or check the website at www.fieldcontrols.com.
3. Next, adjust the VRV gate by screwing the adjustment weight in until the VRV gate is just closed.
4. Re-check the burners operation and adjust accordingly.
5. Lock the adjustment weight in position by tightening the hex nut on the VRV gate.

TROUBLE SHOOTING

PROBLEM:

Low CO² after AIR BOOT™ installation.

Solution:

1. Burner gaskets improperly installed. Check ring gasket to burner housing.
2. Flow restrictor pan not installed on Beckett Burners only with inputs to .75 or less.

PROBLEM:

Pump coupler failure or noisy right after installation.

Solution:

1. Oil pump mounting bolts are over torqued or unevenly torqued.
2. Face gasket has been installed unevenly.
3. Check burner fan wheel. It may be out of balance. Probably bent and needs to be replaced.
4. Supplied coupling was not installed.

REPLACEMENT PARTS

The following items are available for replacement, if needed. In order to replace these parts, power must be disconnected and the unit must be disassembled. If this is necessary, take note of the positions and locations of whatever items that may need to be removed to replace other items. If in doubt, please consult the Field Controls Technical Support at 1-800-742-8368.

Item Description	Field Part Number
VRV-4	46257100
IAH-4	46292000

NOTES:

INSTALLATION INFORMATION

MODEL NO.: _____ CAS-2B, 2C, or 2W _____

INSTALLER'S NAME: _____

INSTALLER'S COMPANY: _____

INSTALLER'S PHONE NO.: _____

DATE OF INSTALLATION: _____



FIELD CONTROLS
The Venting Solutions Company™